

GLASS DOOR MERCHANDISER REFRIGERATOR MULTIPLE SWING DOORS

Project Name: _____

Project Location: _____

Model #: _____ Quantity: _____

Available Warehouse: _____

EM Series

Model: EMSGR33



Refrigeration System

- Bottom mounted, self-contained and fully detachable Blizzard R290 condensing unit uses environmentally friendly, EPA-compliant R290 refrigerant with zero (0) Ozone Depletion Potential (ODP) and three (3) Global Warming Potential (GWP). Blizzard R290 is easily replaceable and requires no on-site brazing.
- Electronically commutated (ECM) fan motors achieve rapid cooling with less energy consumption.
- Full-length air duct ensures optimal cold air distribution.
- Air circulation guard keeps floor vents from obstruction.
- Time-initiated and temperature-terminated auto defrost cycle for seamless operation.
- Large capacity, corrosion-resistant condenser and evaporator coils.
- Self-maintaining, energy-efficient condensate drain pan requires no external drains or electric heaters.
- High performance, auto-reverse condenser fan motor supports compressor ventilation and condenser coil cleaning.
- Pre-wired and ready to plug, 115V/60Hz/1Ph, NEMA 5-15P.

Cabinet Construction

- Heavy duty white coated steel interior / exterior.
- Open spaced interior with no walls between compartments.
- Stainless steel floor interior has rounded corners and detachable drain plug for ease of cleaning.
- 2.5" thick high density polyurethane insulation.
- Four height adjustable screw legs.

Lighting

- Shielded LED bar lighting with on/off switch provides bright, high color illumination at lower heat output.

Doors

- Low emissivity double glass panes reflect UV rays for efficient cooling.
- Black PVC door frames.
- Self-closing with adjustable torsion system for a positive seal.
- Snap-in magnetic door gasket make cleaning and replacement an easy process.
- High strength, die-cast door handles.

Shelving

- Four epoxy coated, steel wire shelves with airflow guard per section.
- Height adjustable stainless steel clips.

Temperature Control

- Multi-function digital controller with easy to read LED display.
- Factory preset temperature, 35°F. Temperature setting range from 33°F to 54°F.
- Audible overheat protection alarm for compressor and condenser coil.

Options

- Additional shelving.
- 3" swivel casters with locks.
- 3.5" – 6" height-adjustable and interchangeable legs.
- NAMA certified, NSF compliant Health Timer Lock



Please visit our website for updated Energy Efficiency information

Ref/ Frz/Dual	Doors	Capacity		Shelves	Refrigerant	HP	Power V-Hz-Ph	Amps	Crated Weight	Exterior Dimensions		
		Cu. Ft.	20 oz. Bottles							L	D	H*
REF	2	36	336	8	R-290	1/3	115-60-1	2.5	433 lbs (196kg)	39.375" (1000mm)	32" (813mm)	80.125" (2035mm)

(†)Based on evaporating temperature of 23°F (-5°C) & condensing temperature of 131°F (55°C). (►) Product capacity is calculated based on standard industry figures. (✳) Reference plan view for clarification on caster/unit height. If dimensions and capacity are critical, please contact Everest Refrigeration. Blizzard R290 replacement is at the sole discretion of Everest Refrigeration. Specifications subject to change without notice.

GLASS DOOR MERCHANDISER REFRIGERATOR

MULTIPLE SWING DOORS

EM Series Model: EMSGR33

DIMENSIONAL DATA

External Dimensions	L	39.375" (1000mm)
	D	32" (813mm)
	H*	80.125" (2035mm)
Crated Weight		433 lbs. (196kg)
Doors/Drawers/Lids		2
Max Weight Support (LBS)		-

STORAGE DATA

Net Capacity Cu. Ft. ▶	36
Shelves	8
Barrels	-
20 oz. Bottles	336
12 oz. Bottles	-
12 oz. Cans	-
8" Mugs	-
# of Pans (Top)	-
# of Pans (Drawer)	-
Dividers	-
Trays	-

ELECTRICAL DATA

Voltage	115-60-1
Full Load Amperage	2.5A
Feed Wires with Ground	3
Cord Length	9ft
NEMA Plug Type	 NEMA 5-15P

REFRIGERATION DATA

Compressor Mounting	Bottom
Refrigerant	R-290
Compressor HP	1/3
BTU/HR †	N/A

KEY

D	Door	R	Refrigerator
L	Lid	REF	Refrigerator
H	Half Door	F	Freezer
FD	Full Door	FRZ	Freezer
SD	Solid Door	DUAL	REF/FRZ Combo
GD	Glass Door	DR	Drawer

	Elevation	Right	Plan	3D	Back

PLAN VIEW

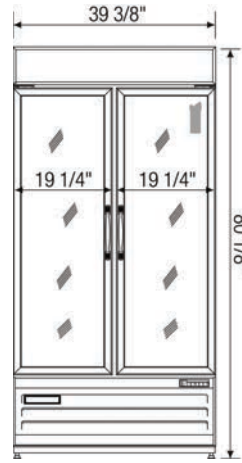

FRONT

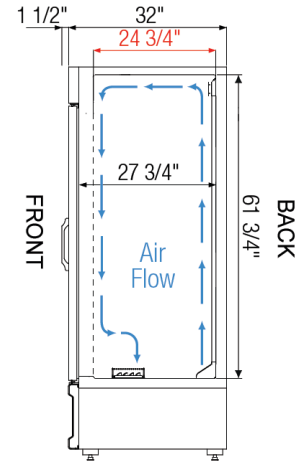

SIDE

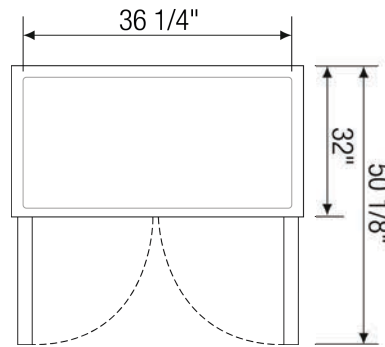

TOP

ACCESSORIES & OPTIONS

Part Number	Description
Additional Shelving	Contact Everest Refrigeration for more information.
AJL03-00	Interchangeable Leg for Caster (Optional)
CASA3-01	3" Overall Height Caster Assembly - (2) Front (2) Rear
HL02-00*	Health timer lock for double door
HLK01-00*	Health timer lock key (remote controller)

(†) Based on evaporating temperature of 23°F (-5°C) & condensing temperature of 131°F (55°C). (▶) Product capacity is calculated based on standard industry figures. (✳) Reference plan view for clarification on caster/unit height. If dimensions and capacity are critical, please contact Everest Refrigeration. Blizzard R290 replacement is at the sole discretion of Everest Refrigeration. Specifications subject to change without notice.